

# RADIAL-GELENKLAGER DIN ISO 12240-1 Maßreihe E

## Gleitpaarung: Hartchrom/PTFE Gewebe >> wartungsfrei GE ... UK-2RS

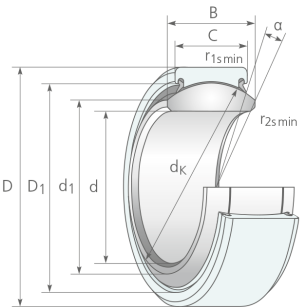

Lagerluftgruppen [µm] GE ... UK-2RS

d [mm]	CN
17 < d ≤ 20	0 bis 40
20 < d ≤ 35	0 bis 50
35 < d ≤ 60	0 bis 60
60 < d ≤ 90	0 bis 72
90 < d ≤ 140	0 bis 85
140 < d ≤ 240	0 bis 100
240 < d ≤ 300	0 bis 110

Weitere Lagerluftgruppen auf Anfrage

Einbaubedingungen GE ... UK-2RS

Material	Welle aus Stahl	Gehäuse aus Stahl	Gehäuse aus Leichtmetall
Gültig für Wellen-Ø	17 ≤ d ≤ 300 mm	17 ≤ d ≤ 300 mm	17 ≤ d ≤ 300 mm
Oberflächenqualität	≤ Rz 10	Rz 10 bis Rz 16	Rz 10 bis Rz 16
Einbaupassung bei Lagerluftgruppe	j6	K7	M7

	d	D	B	C	d K	??	r1s min	r2s min	m	C	C 0	? d 1	? D 1
	[mm]	[mm]	[mm]	[mm]	[mm]	[°]	[mm]	[mm]	[kg]	[kN]	[kN]	[mm]	[mm]
GE 17 UK-2RS	17	30	14	10	25,0	10	0,3	0,3	0,041	48,7	81,2	20	24,0
GE 20 UK-2RS	20	35	16	12	29,0	9	0,6	0,3	0,066	67,5	112,0	24	27,5
GE 25 UK-2RS	25	42	20	16	35,5	7	0,6	0,6	0,119	127,0	212,0	29	33,0
GE 30 UK-2RS	30	47	22	18	40,7	6	0,6	0,6	0,153	165,0	275,0	34	38,0
GE 35 UK-2RS	35	55	25	20	47,0	6	0,6	1,0	0,233	210,0	350,0	39	44,5
GE 40 UK-2RS	40	62	28	22	53,0	7	0,6	1,0	0,306	277,0	462,0	45	51,0
GE 45 UK-2RS	45	68	32	25	60,0	7	0,6	1,0	0,427	360,0	600,0	50	57,0
GE 50 UK-2RS	50	75	35	28	66,0	6	0,6	1,0	0,546	442,0	737,0	55	63,0
GE 60 UK-2RS	60	90	44	36	80,0	6	1,0	1,0	1,040	690,0	1150,0	66	75,0
GE 70 UK-2RS	70	105	49	40	92,0	6	1,0	1,0	1,550	885,0	1475,0	77	87,0
GE 80 UK-2RS	80	120	55	45	105,0	6	1,0	1,0	2,310	1125,0	1875,0	88	99,0
GE 90 UK-2RS	90	130	60	50	115,0	5	1,0	1,0	2,750	1380,0	2300,0	98	108,0
GE 100 UK-2RS	100	150	70	55	130,0	7	1,0	1,0	4,450	1717,0	2862,0	109	123,0
GE 110 UK-2RS	110	160	70	55	140,0	6	1,0	1,0	4,820	1845,0	3075,0	120	134,0
GE 120 UK-2RS	120	180	85	70	160,0	6	1,0	1,0	8,050	2685,0	4475,0	130	150,0
GE 140 UK-2RS	140	210	90	70	180,0	7	1,0	1,0	11,020	3015,0	5025,0	150	173,0
GE 160 UK-2RS	160	230	105	80	200,0	8	1,0	1,0	14,010	3840,0	6400,0	170	191,0
GE 180 UK-2RS	180	260	105	80	225,0	6	1,1	1,1	18,650	4320,0	7200,0	192	219,0
GE 200 UK-2RS	200	290	130	100	250,0	7	1,1	1,1	28,030	6000,0	10000,0	212	239,0

GE 220 UK-2RS	220	320	135	100	275,0	8	1,1	1,1	35,510	6600,0	11000,0	238	267,0
GE 240 UK-2RS	240	340	140	100	300,0	8	1,1	1,1	39,910	7200,0	12000,0	265	295,0
GE 260 UK-2RS	260	370	150	110	325,0	7	1,1	1,1	51,540	8550,0	14250,0	285	319,0
GE 280 UK-2RS	280	400	155	120	350,0	6	1,1	1,1	65,060	10050,0	16750,0	310	342,0
GE 300 UK-2RS	300	430	165	120	375,0	7	1,1	1,1	78,070	10800,0	18000,0	330	370,0