

UCPW 201 ... UCPW 210 STEHLAGER, GUSSGEHÄUSE

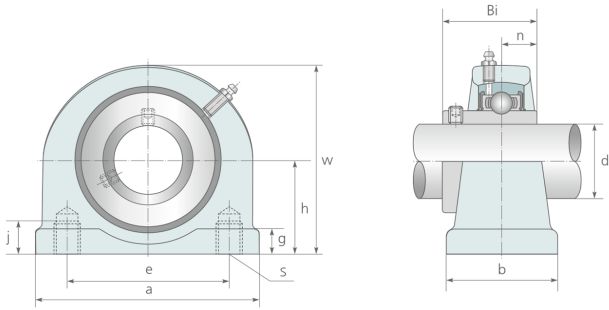

	Abmessungen [mm]											Tragzahl [kN]		Gewicht [kg]		
	d[mm]	h	a	e	b				Bi	n	S Schraube	Lager	Gehäuse		dyn.C	stat.C0
UCPW 201	12	33,3	73,0	50,8	38,0	12	13	65,0	31,0	12,7	M10	UC 201	PW 201	12,8	6,7	0,63
UCPW 202	15	33,3	73,0	50,8	38,0	12	13	65,0	31,0	12,7	M10	UC 202	PW 202	12,8	6,7	0,63
UCPW 203	17	33,3	73,0	50,8	38,0	12	13	65,0	31,0	12,7	M10	UC 203	PW 203	12,8	6,7	0,63
UCPW 204	20	33,3	73,0	50,8	38,0	12	13	65,0	31,0	12,7	M10	UC 204	PW 204	12,8	6,7	0,63
UCPW 205	25	36,5	76,2	50,8	38,0	12	13	71,4	34,0	14,3	M10	UC 205	PW 205	14,0	7,9	0,80
UCPW 206	30	42,9	101,6	76,2	47,6	15	16	85,7	38,1	15,9	M12	UC 206	PW 206	19,5	11,3	1,20
UCPW 207	35	47,6	108,0	82,5	47,6	16	19	95,2	42,9	17,5	M14	UC 207	PW 207	25,7	15,4	1,70
UCPW 208	40	49,2	117,5	88,9	47,6	16	19	100,0	49,2	19,0	M14	UC 208	PW 208	32,0	17,8	2,00
UCPW 209	45	54,0	127,0	95,3	50,8	18	19	108,0	49,2	19,0	M14	UC 209	PW 209	32,7	20,2	2,20
UCPW 210	50	57,2	139,7	101,6	50,8	18	25	117,5	51,6	19,0	M16	UC 210	PW 210	35,1	23,1	2,80